



# Mini MIXER

MINIMIX 150 - boxed  
or assembled

**MINIMIX 150**

Belle Group's range of concrete mixers has proven appeal to the professional, rental and DIY user.

Offering portable, quality mixers for any building requirement.

Lightweight but effective the Minimix 150 operates in confined spaces, at barrow height on the stand, or simply wheeled to the job.

The best selling mixer for construction and rental.



# MINIMIX 150

Belle Group Products are 'Built for the Job', with a proven reputation for high quality whatever your building requirement.



■ Wheeled for easy transport



■ Operates in confined spaces



■ Portable stand allows barrow height mixing and tipping



■ Easy access cover top for fuel and maintenance



■ Proven gearbox.  
■ Increased motor protection (IP45).



■ Safe and simple assembly



■ Portable and light, compact enough for the car boot



■ Available boxed for easy stocking and transport

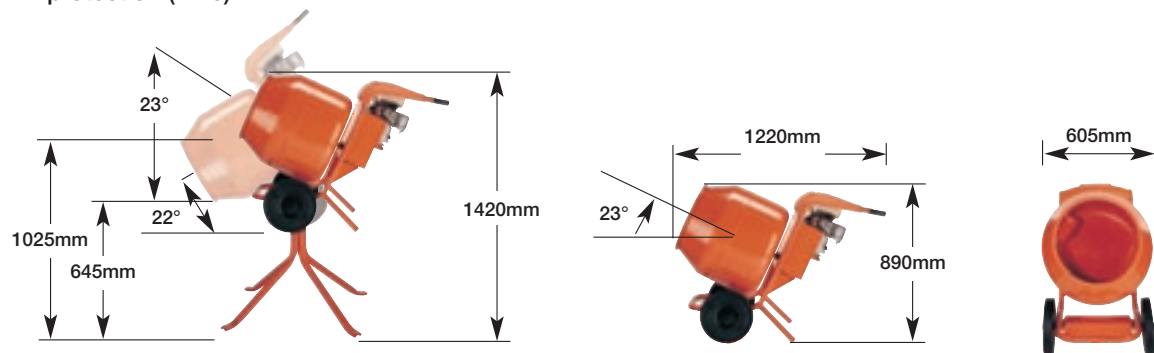

PERFORMANCE DATA	MINIMIX Electric	MINIMIX Petrol
Max Drum Cap	136 L	136 L
Max Mix Cap	90 L	90 L
Drum Speed (RPM)	24	24
Noise Level	< 70dB(A)	< 87dB(A)
Engine/Power	110V/230V/415V	Petrol
Weight	57 kg	61 kg
Height off stand	890 mm	890 mm
Height on stand	1420 mm	1420 mm
Width	605 mm	605 mm
Length	1220 mm	1220 mm

**POWER UNIT OPTIONS (all models)**  
 230V 50Hz (option 230v 60Hz). 110V 50Hz (option 110V 60Hz). 415V 50Hz.  
 All double insulated. IP45 rated.  
 Petrol: Honda G100 / Briggs & Stratton IC / Robin EY08

Shipping Dimensions	
<b>(Boxed only)</b>	
(box contains mixer and stand)	
<b>Electric Motor Version</b>	
Length	915mm
Width	600mm
Height	725mm
<b>Petrol Engine Version</b>	
Length	915mm
Width	600mm
Height	960mm

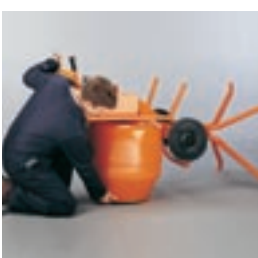

BELLE GROUP, SHEEN, NR BUXTON, DERBYSHIRE, SK17 0EU, ENGLAND  
 Tel: +44 (0)1298 84606 Fax: +44 (0)1298 84722 email: sales@belle-group.co.uk www.belle-group.co.uk  
 Belle Group reserve the right to amend or improve any specifications in this brochure without notice.